

### Which product should I choose?

<b>COMFORT~ONE™ HEATED FLOOR</b>	<ul style="list-style-type: none"><li>- Indoor use.</li><li>- Installation while installing the floor covering.</li><li>- Ideal for surfaces of every shape.</li><li>- The best solution for primary or auxiliary heating.</li></ul>
<b>COMFORT~ONE™ HEATING MAT</b>	<ul style="list-style-type: none"><li>- Indoor use.</li><li>- Installation while installing the floor covering.</li><li>- Ideal for square or rectangular surfaces.</li><li>- The best solution for primary or auxiliary heating.</li></ul>
<b>COMFORT~ONE™ SUBFLOOR CABLE</b>	<ul style="list-style-type: none"><li>- Indoor use.</li><li>- Installation without installing floor covering.</li><li>- Installed between the floor joists.</li><li>- The best solution for auxiliary heating.</li></ul>
<b>COMFORT~ONE™ SNOW MELTING CABLE</b>	<ul style="list-style-type: none"><li>- Outdoor use.</li><li>- Installation while installing the cladding.</li><li>- Ideal for surfaces of every shape.</li><li>- The best solution for melting snow and ice.</li></ul>

**How do I calculate the surface to cover?**

- 1) Produce a scale drawing.
- 2) Calculate the total area (length x width).
- 3) Calculate the area occupied by fixed elements.
- 4) Calculate the angles to cover.
- 5) Subtract the area of the fixed elements from the total area.
- 6) Multiply the result by 0.96 to obtain the total area to cover.

Example :

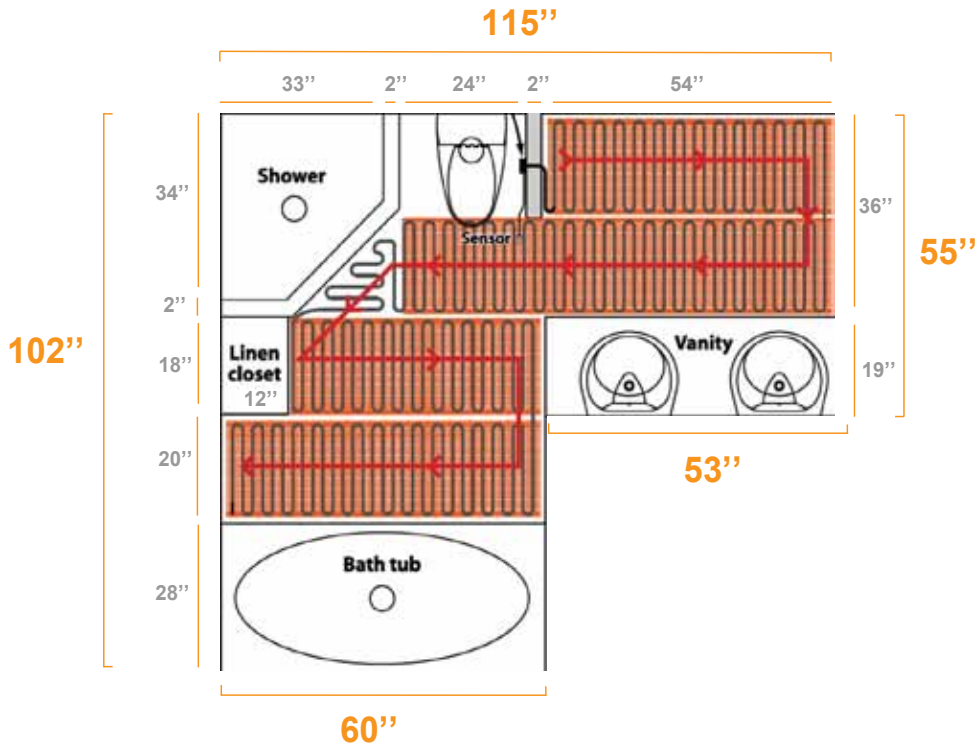

Total area	Length	Width	Subtotal
Bathroom	102 po	115 po	$11\,730\text{ po}^2 + 144 = 81,50\text{ pi}^2$
Lost space	48 po	53 po	$2\,544\text{ po}^2 + 144 = 18\text{ pi}^2$
Total			$81,5\text{ pi}^2 - 18\text{ pi}^2 = 63,5\text{ pi}^2$

Fixed elements	Length	Width	Subtotal	Angle to cover	TOTAL
Shower	36 po	35 po	$1\,260\text{ po}^2 + 144 = 8,75\text{ pi}^2$	$(23\text{ po} \times 18\text{ po} + 2) + 144 = 1,5\text{ pi}^2$	$7,25\text{ pi}^2$
Bath	60 po	28 po	$1\,680\text{ po}^2 + 144 = 12\text{ pi}^2$	-	$12\text{ pi}^2$
Vanity	53 po	19 po	$1\,007\text{ po}^2 + 144 = 7\text{ pi}^2$	-	$7\text{ pi}^2$
Toilet	24 po	18 po	$432\text{ po}^2 + 144 = 3\text{ pi}^2$	-	$3\text{ pi}^2$
Cabinet	12 po	18 po	$216\text{ po}^2 + 144 = 1,5\text{ pi}^2$	-	$1,5\text{ pi}^2$
Total					$30,75\text{ pi}^2$

Maximum surface to cover :  $63,5\text{ pi}^2 - 30,75\text{ pi}^2 = 32,75\text{ pi}^2 \times 0,96 = 31,50\text{ pi}^2$

## Pro tips:

- Take all measurements in inches to ensure a more precise calculation.
- Do not install the cables underneath cabinets or sanitary facilities or inside a wall.
- Do not install the cables in small cabinets or other confined spaces.
- Install the cable about 3.8 to 5.08 cm (1 ½ to 2 in.) from a counter or a vanity.
- Do not install the cables less than 15.2 cm (6 in.) from each side of a wax bowl ring and less than 30.5 cm (12 in.) from the front and back of the bowl.
- In open areas, such as solariums or sunrooms, install the cables 6.35 cm (2.5 in.) from the perimeter of the room.

## Important!

**Opt for a cable that will cover an area equivalent to or smaller than the surface you want to cover.** If you do not find a length that corresponds to your surface, choose the next smallest length. The cables must never be cut, crossed or altered. A scale drawing is your best tool to calculate the surface to cover.

## Quick reference

### Area of a square

Multiply the length of one of its sides by itself.

Shower example:

$$48 \text{ po} \times 48 \text{ po} = 2304 \text{ po}^2$$

### Area of a rectangle

Multiply the length by the width.

Vanity example:

$$108 \text{ po} \times 21 \text{ po} = 2268 \text{ po}^2$$

### Area of a triangle

Multiply the base by the height and divide by 2.

Bathtub angle example:

$$30 \text{ po} \times 30 \text{ po} = 900 \text{ po}^2$$

### Conversion into ft<sup>2</sup>

$$\text{po}^2 \div 144 = \text{ft}^2$$

## How do I choose the right spacing?

When you order the cable, you must know the type of room where your system will be installed. It is also important to know the floor base. This data has a direct effect on the spacing to be maintained between cable runs, and thus determines what cable length to order.

### Pro tip

Never place the cables less than 6.35 cm (2.5 in.) apart, because this will create a very hot area that could cause damage.

## Technical specifications

Installation surface	Floor covering							
<b>Heated floor</b> Suggested spacing	ceramic tiles	natural stone	engineered wood*	vinyl*	floating floor*	linoleum*	parquetry*	carpet**
plywood	3	3	3.5	3.5	3.5	3.5	3.5	3.5
smooth concrete	3	3	3.5	3.5	3.5	3.5	3.5	3.5
concrete panels	3	3	3.5	3.5	3.5	3.5	3.5	3.5
ceramic tiles	3	3	3.5	3.5	3.5	3.5	3.5	3.5
acoustic membrane	3	3	3.5	-	3.5	-	3.5	3.5
anti-fracture membrane	3	3	3.5	-	3.5	-	3.5	3.5
mortar bed	3	3	3.5	3.5	3.5	3.5	3.5	3.5
scratch coat (preglazed mesh)	3	3	3.5	3.5	3.5	3.5	3.5	3.5
sunroom / solarium	2.5	2.5	3.5	3.5	3.5	3.5	3.5	2.5

\*(preglazed mesh subfloor)

\*\* (without rubber backing or underpad)

Installation surface	Floor covering							
<b>Heating mat</b> Suggested spacing	ceramic tiles	natural stone	engineered wood*	vinyl*	floating floor*	linoleum*	parquetry*	carpet**
plywood	✓	✓	✓	✓	✓	✓	✓	✓
smooth concrete	✓	✓	✓	✓	✓	✓	✓	✓
concrete panels	✓	✓	✓	✓	✓	✓	✓	✓
ceramic tiles	✓	✓	✓	✓	✓	✓	✓	✓
acoustic membrane	✓	✓	✓	-	✓	-	✓	✓
anti-fracture membrane	✓	✓	✓	-	✓	-	✓	✓
mortar bed	✓	✓	✓	✓	✓	✓	✓	✓
scratch coat (preglazed mesh)	✓	✓	✓	✓	✓	✓	✓	✓

\*(preglazed mesh subfloor)

\*\* (without rubber backing or underpad)

## Technical specifications

Installation surface	Floor covering							
<b>Subfloor</b> Predefined spacing	ceramic tiles	natural stone	engineered wood*	vinyl	floating floor*	linoleum	parquetry	carpet*
	✓	✓	✓	✓	✓	✓	✓	✓

\*(without rubber backing or underpad)

Installation surface	Floor covering		
<b>Snow melting cable</b> Suggested spacing	ceramic tiles	natural stone	ciment
	3/4	3/4	3/4

## Typical spacing by room

Living space	Spacing
Bathroom	2,5 or 3
Kitchen	2,5 or 3
Living room	2,5 or 3
Solarium*	2,5
Corridor	3 or 3,5
Entrance	3 or 3,5
Large rooms with low heat loss	3 or 3,5

\*Solarium: The performance of the COMFORT~ONE™ heating system is never guaranteed, due to differences in construction and climate. To avoid heat losses, we do not recommend insulating the subfloor.

## How do I calculate the necessary cable strap?

COMFORT~ONE™ cable straps are designed to simplify installation and maintain uniform spacing between the cables.

In all, 4 models are offered to meet your project's spacing needs: 2.5 in., 3 in., 3.5 in. and 4 in.

A box of 25 linear ft of cable strap covers a surface of 40 ft<sup>2</sup>.

To ensure that you order enough cable strap material, calculate the number of boxes according to the number of ft<sup>2</sup> to cover.

Cable strap – 7.6 m (25 linear ft) per box	Surface covered
1 box	40 pi <sup>2</sup>
2 boxes	80 pi <sup>2</sup>
3 boxes	120 pi <sup>2</sup>
4 boxes	160 pi <sup>2</sup>
5 boxes	200 pi <sup>2</sup>
10 boxes	400 pi <sup>2</sup>
25 boxes	1 000 pi <sup>2</sup>

## Warning

- NEVER cut a heating cable.
- NEVER use nails, staples or similar assembly parts to fasten the heating cable to the floor.
- NEVER strike the heating cable with a trowel or any other tool.
- Be careful not to snag, cut or pinch the cable. This could damage it.
- NEVER install cables underneath cabinets or other recessed articles. Excessive heat will form underneath these articles and could cause damage.
- NEVER install cable inside the walls, on walls or partitions that extend to the ceiling, or inside the cabinets.
- NEVER extend the heated part of the cable beyond the room or the area where it starts.
- NEVER try to repair a damaged cable. Contact our Technical Support Service for assistance.
- NEVER overlap the heating cables. This would cause dangerous overheating.
- NEVER allow a current-carrying wire or a sensor wire to cross a heating cable.
- NEVER embed the cables in adhesives for laminates or vinyl floors. Exclusively use a polymer-modified mortar or a self-leveling cement.
- NEVER apply the wrong voltage to a cable.
- NEVER use spacing of less than 6.35 cm (2.5 cm).
- ALWAYS embed the heating cable and the factory connection completely in the mortar.
- ALWAYS maintain at least 6.35 cm (2.5 in.) of spacing between the cables.
- ALWAYS use copper for power conductors to the control and to the cable. Do not use aluminium.
- ALWAYS focus on the voltage and amperage requirements of the circuit-breaker, the control and the cable system.
- ALWAYS test the cable resistances and record them in the Sensor and Cable Resistance Log.

## Pro tip

Entrust electrical installation to a certified electrician. The local codes may require that an electrician install or connect the cable or the thermostat control, in order to comply with the local construction codes, the US National Electrical Code (NEC), especially section 424, Part IX, and section 62 of the Canadian Electrical Code (CEC), Part 1.

## Important!

- Choose between 120 VAC and 240 VAC, depending on the available current.
- DO NOT mix voltages.
- DO NOT install more than 15 A per control.